

3RXXAT-A

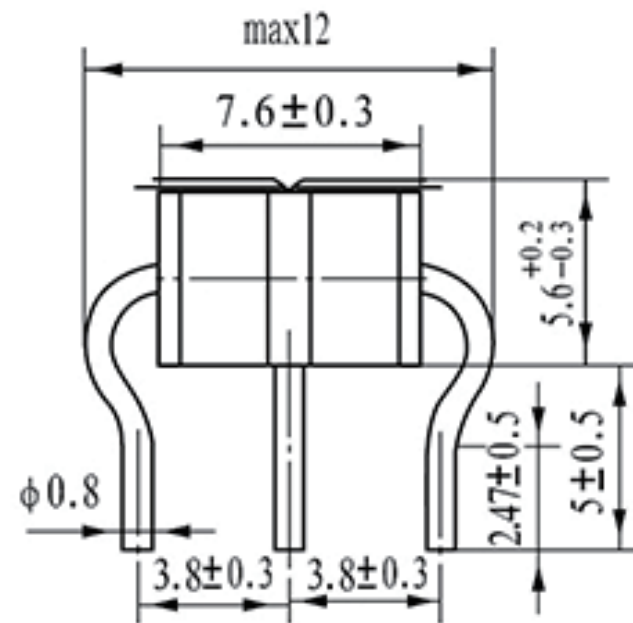

3RXXAT-AF

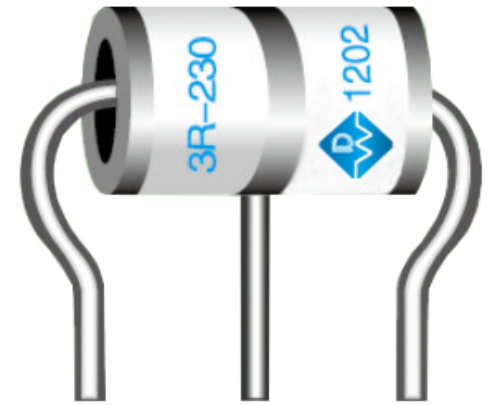

项目 Item	规格 Specification						单位 Unit
	3R75 AT-A	3R90 AT-A	3R150 AT-A	3R230 AT-A	3R350 AT-A	3R420 AT-A	
	3R75 AT-AF	3R90 AT-AF	3R150 AT-AF	3R230 AT-AF	3R350 AT-AF	3R420 AT-AF	
标称直流击穿电压 Nominal DC Spark-over Voltage (100V/S)	75 ± 20%	90 ± 20%	150 ± 20%	230 ± 20%	350 ± 20%	420 ± 20%	V
最大冲击击穿电压 Maximum impulse spark- over voltage (1KV/us)	550	550	550	600	850	950	V
耐冲击电流 (短波) (a+b)-e Impulse discharge current (8/20us, 10 times)	5/10	5/10	5/10	5/10	5/10	5/10	KA
耐冲击电流 (长波) (a+b)-e Impulse discharge current (10/1000us, 300 times)	100	100	100	100	100	100	A
耐交流电流(a+b)-e AC discharge current (50Hz, Is, 10 times)	5/10	5/10	5/10	5/10	5/10	5/10	A
最小绝缘电阻 Minimum insulation resistance	1000	1000	1000	1000	1000	1000	MΩ
最大极间电容 Maximum capacitance (1MHZ)	1.5	1.5	1.5	1.5	1.5	1.5	pF
最大横向电压延迟时间 Maximum transverse Voltage duration	200	200	200	200	200	200	ns